

Steel Bar Bender
GW40/42/50/60/70

User's Manual

www.safe-salon.ru

Dear Owner

Thanks for choosing our products. Before operating the bender, be sure to read and familiar with the manual carefully, otherwise injury to personnel or damage to equipment may occur.

Notice:

This manual is only suitable for operating and maintenance of GW40/42/50/60/70 steel bar bender.

- This manual is a part of this machine. It can't be separated from the machine whenever you purchase or resell this bender.
- We reserve the right to change some of the contents in this manual without giving advanced notice.

Section One Main Parameter

Items	GW40	GW42	GW50	GW60	GW70
Diameter of Round Steel (mm)	Φ6-Φ40	Φ6-Φ40	Φ6-Φ45	Φ20-Φ60	Φ28-Φ70
Diameter of Deformed Steel (mm)	Φ6-Φ32	Φ6-Φ32	Φ6-38	Φ25-Φ50	Φ28-Φ60
Speed of Main shaft (r/min)	5-15	5-15	5-15	3-8	3-8
Motor Power(kw)	2.2/3	3	4	5.5	5.5
Voltage (V)	220-415	220-415	220-415	380-415	380-415
Weight (kg)	166/239	239/285	337	580	890

Section Two Structure

Main parts of steel bar bender are electric motor , V-belt, gear box ,Accessory(Including working disk and square table) , frame and so on.

Section Three Operation

1. The working method

- The method of bending steel bars

Method of bending steel bars is by inserting different attachments into the Working Disk and insert seat, so that the disk completes a reverse rotation. Accessories are supplied as the following attachment table, methods for bending steel bar in chart 2-7.

Chart 6 shows diagram of bending steel bar in diameter of 6-24mm

Chart 7 shows diagram of bending steel bar in diameter of over 25-70mm.

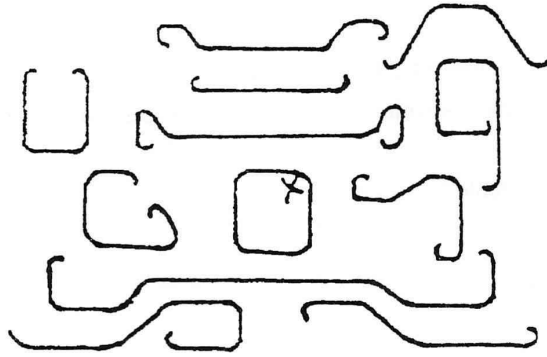

Chart 1. The common shapes of bending steel barre using

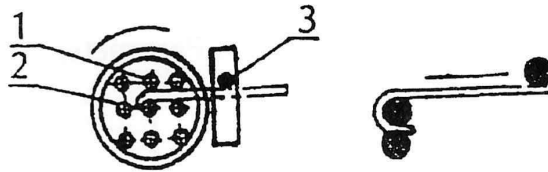
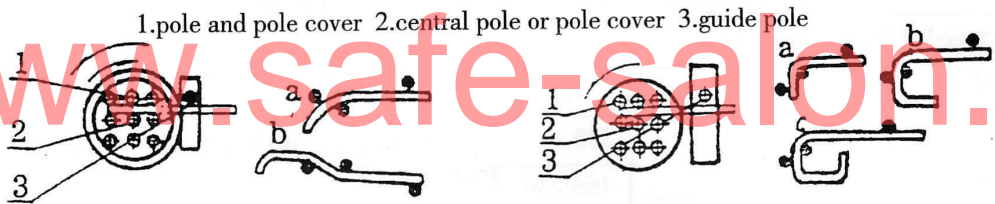

Chart 2



1.pole and pole cover 2.central pole or pole cover 3.guide pole



Chart 3



Chart 4

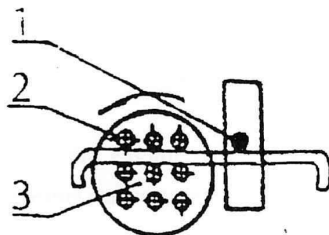
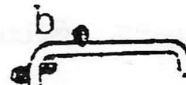
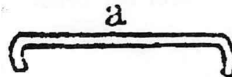

Chart 5

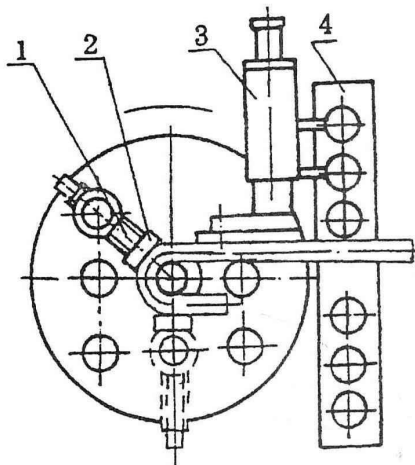

Chart 6

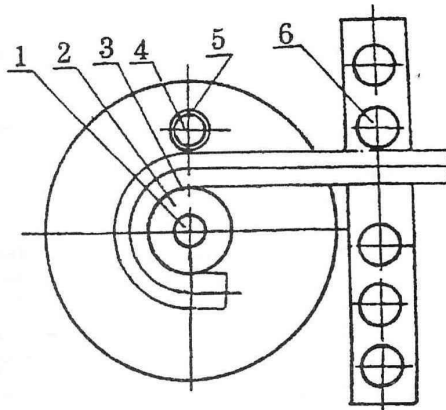

Chart 7

Attachment table

● The tool selection for Bending round Steel $\phi 25 - \phi 36$

Diameter of steel bar(mm) Position Name	$\phi 25$			$\phi 28$			$\phi 32$			$\phi 36$		
	Working disk center	Working disk	Insert seat	Working disk center	Working disk	Insert seat	Working disk center	Working disk	Insert seat	Working disk center	Working disk	Insert seat
Central pole	✓	✓	✓	✓	✓	✓	✓	✓	✓	✓	✓	✓
$\phi 96$ pole cover(1)					✓					✓		
$\phi 77$ Pole Cover(2)	✓			✓			✓			✓		
$\phi 63$ pole cover(3)			✓			✓		✓			✓	

● The tool selection for bending II deformed steel $\phi 25 - \phi 36$

Diameter of steel bar(mm) Position Name	$\phi 25$			$\phi 28$			$\phi 32$			$\phi 36$		
	Working disk center	Working disk	Insert seat	Working disk center	Working disk	Insert seat	Working disk center	Working disk	Insert seat	Working disk center	Working disk	Insert seat
Central pole	✓	✓	✓	✓	✓	✓	✓	✓	✓	✓	✓	✓
$\phi 96$ pole cover(1)					✓					✓		
$\phi 77$ Pole Cover(2)	✓			✓			✓			✓		
$\phi 63$ pole cover(3)			✓			✓		✓			✓	

● Minimum bending radius for Central pole

Diameter of steel (mm)	φ 6	φ 6	φ 10	φ12- φ14	φ16- φ18	φ 20	φ22- φ25	φ25- φ28	φ 32
Minimum bend radius (mm)	R8	R10	R12.5	R22.5	R22.5	R25	R30	R37.5	R42.5
Central pole(mm)	φ 24	φ 24	φ 24	φ 38	φ 38	φ 63	φ 63	φ 77	φ 77

● Minimum bending radius for Central pole

Diameter of steel (mm)	φ 8	φ 10	φ 12	φ 14	φ 16	φ18- φ20	φ22- φ25	φ25- φ28	φ 32
Minimum bend radius (mm)	R12	R15	R18	R21	R24	R30	R36	R42	R48
Central pole(mm)	φ 24	φ 28	φ 38	φ 38	φ 63	φ 63	φ 77	φ 96	φ 96

2. Preparation before operation

1) There must be enough space and the ground must be smooth which will ensure the operation convenience and the equipment's bottom is indeed on the ground.

2) Before operating, the machine's spare parts should be checked whether it's broken or loose and the electrical wiring is safe and the electric motor connect earth wire. Installing earth leakage circuit breaker before using

3) To check if there is enough oil in the case and the oil cup of main shaft

4) At the first operation, the equipment should run no-load 15 to 30 minutes. During the period, user check whether abnormal noise and phenomenon exists and the button is sensitive and effective.

5) Before the normal operation, inspection should be done in advance:

● Electrical switch is safe and effective.

● To ensure there's no abnormal noise and phenomenon after the equipment powered on.

6) Operating over-loaded is strictly forbidden.

3. Notice for operation

1.) Bending steel bars must be based on curvature to control the button or adjust the itinerary block, so must control the stop time.

2.) During operation, user has to put the steel bar in correct location, keep straight and do not tilt steel.

3.) Choosing convenience operation location.

4.) If bending steel bars at a large number or a longer size, it should be equipped with self-support rack.

5.) Set ruler on working table in order to reduce the time scale.

Section Four Electric Control System

1. The electrical system is simple, easy to learn, safe and reliable. It has "Back", "stop" and "advance" switch . Automatic switch and travel switch and auto-manual transition switch are used for automatic bender(when the user rotate the auto-manual transition switch to the auto position and touch the automatic switch ,the working disk can be backed to the original location automatically after bending the steel bar.when the user rotate the auto-manual transition switch to the manual position and touch the manual switch,it will become the manual steel bar bender)

2. After power on, when using the "Advance" switch, the disk rotates clockwise and the steel begins to be bent. The machine will stop working when using "stop" switch . when using the "Back" switch ,the working disk will be back to the original location.

Section Five Equipment Maintenance and Repairing

1. User must know the structure, function, operation method and abide by every provision and notice of specification.

2. The equipment should be operated by specially-assigned person. The specially-assigned person shall keep the equipment clean and maintain it at regular intervals and pay attention to operation situation regularly.

3. Clean the iron filings on the working disk in time.

4. In order to avoid poorly applied, Electrician and electric service man should inspect and maintain electric at regular intervals.

5. New machine have been added 4kg calcium base grease, and replaced it after first using 100hours, replaced every three months later. User could see the oil filler on the work disk, then add the calcium base grease after removing the cover of oil filler, or user could see the side cover of gearbox after opening the door of machine, then replace and replenish the calcium base grease after remove.It also need add enough engine oil from oil cup every 4hours(if there is no oil cup,there is no need to add)

6. Stop work, cut off the power switch.

7. When inspecting or maintaining the equipment , live working is forbidden.

8. After using 1500hours, the working disk needs to be changed for 1800 to prolong the service life.Bending steel bars with maximum diameter must be in the heavy duty bending direction and with the lower speed of working disk.

9. Do not use central poles with small diameter to bend steel bars with maximum diameter.

Section Six Packing and Transportation

1. All the exposed surface should be coated with anti-rust oil and should be packed after covering oil-paper.
2. Machines should be certainly kept in a fixed position in the case of collision damage.
3. Interface between the covered paper and wooden box must be taken tightly in order to prevent water-leakage.
4. If it is out work for long time, it should to be put in warehouse or storage shed in order to prevent moisture and dust.
5. Machine should be lifted from the bottom while vibration and incline are not allowed.

Section Seven Wear-out Parts

No.	Name
1	Accessory(Including working disk and square table)
2	Upper shaft sleeve
3	Lower bush
4	Foot wheel
5	V-belt